

ASSEMBLY INSTRUCTIONS

PW/SW200

PARTS LIST:

- (1) BASE W/ CASTERS
- (4) 1-SIDED SLAT WALL PANELS
- (1) CENTER COLUMN
- (1) TOP CAP
- (12) BRONZE CONNECTOR BOLTS
- (1) ALLEN KEY

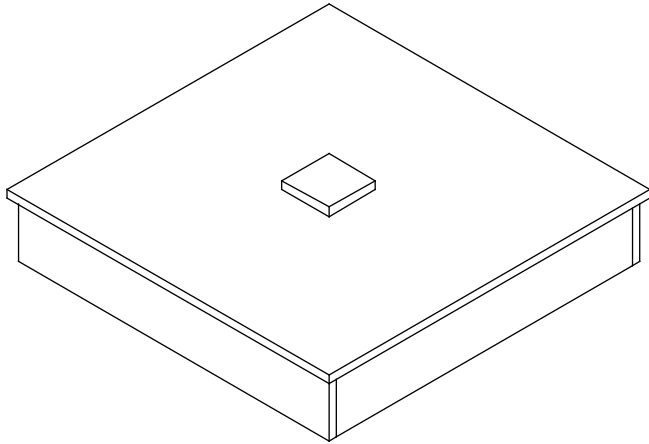

STEP 1: STAND BASE UPRIGHT

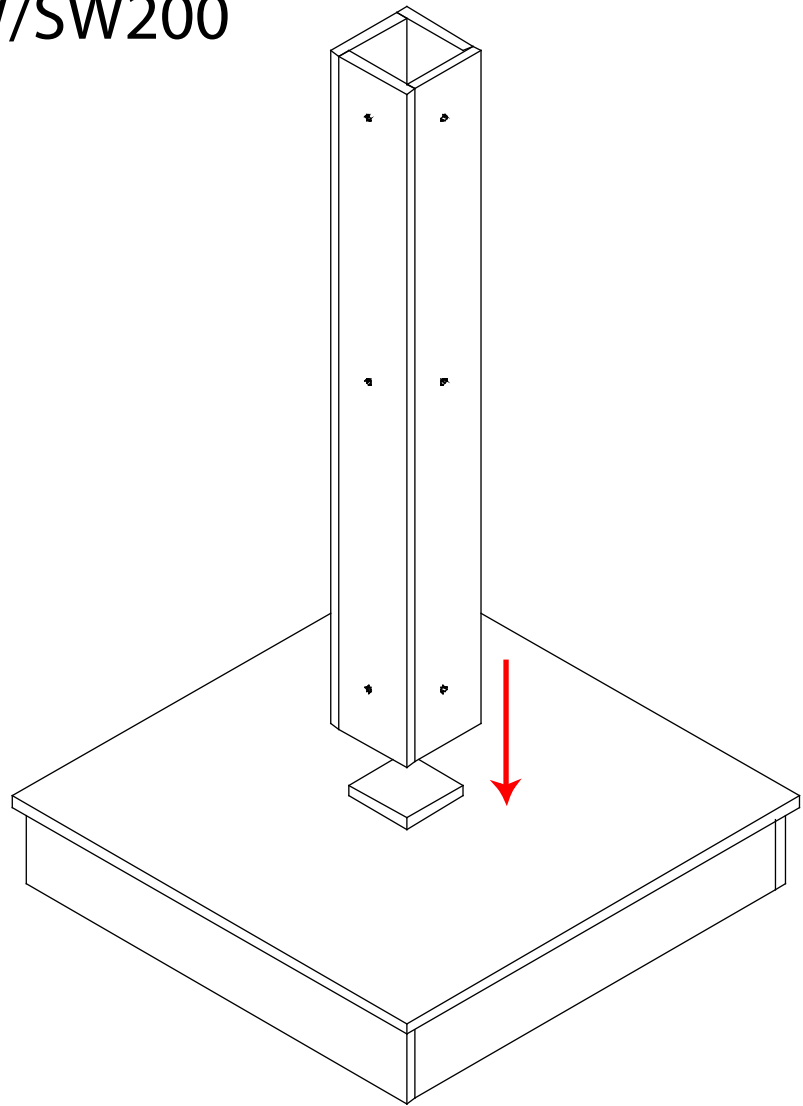

STEP 2: FIT CENTER COLUMN OVERT BLOCK IN CENTER OF BASE. **THE COLUMN HAS A SPECIFIC TOP & BOTTOM.** THE TOP IS THE SIDE ON WHICH THE HOLES ARE CLOSEST TO THE EDGE.

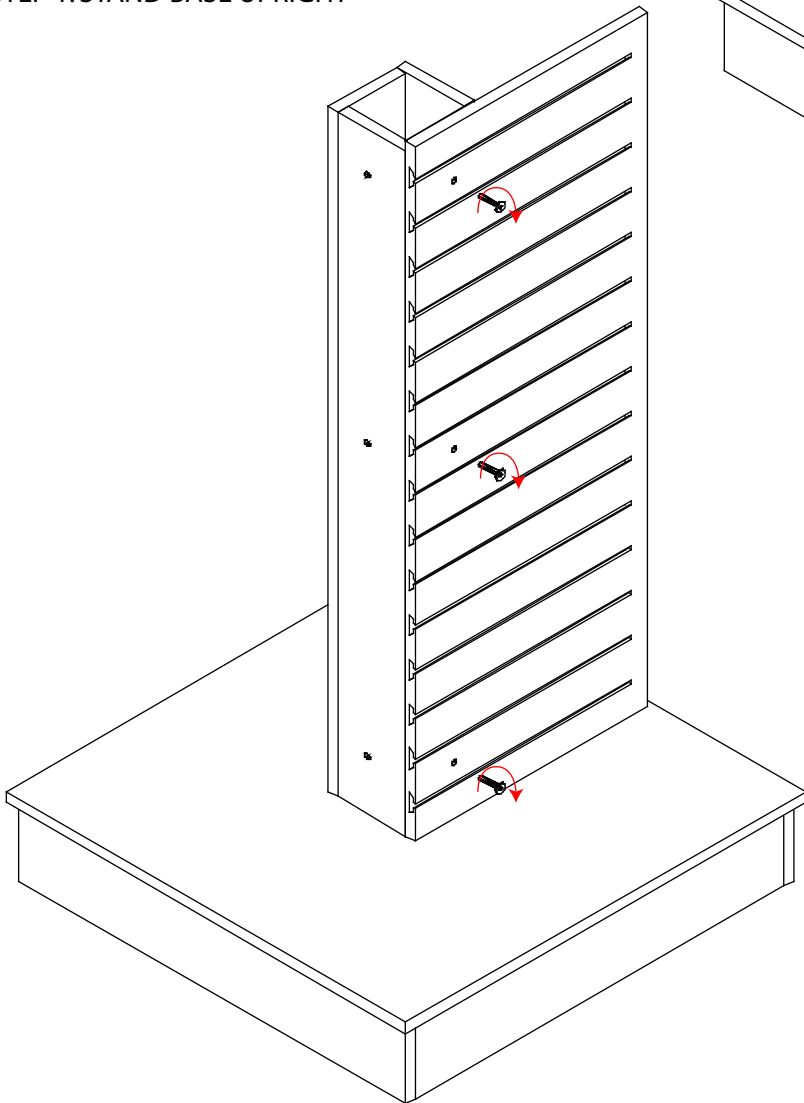

STEP 3: ATTACH THE FIRST SIDE PANEL TO THE CENTER COLUMN. MAKE SURE THAT THE EDGE WHERE THE SLAT WALL GROOVES ARE EXPOSED IS FLUSH WITH THE CENTER COLUMN AS SHOWN. USE 3 BOLTS TO SECURE THE PANEL USE THE ALLEN KEY TO TIGHTEN (PROVIDED)

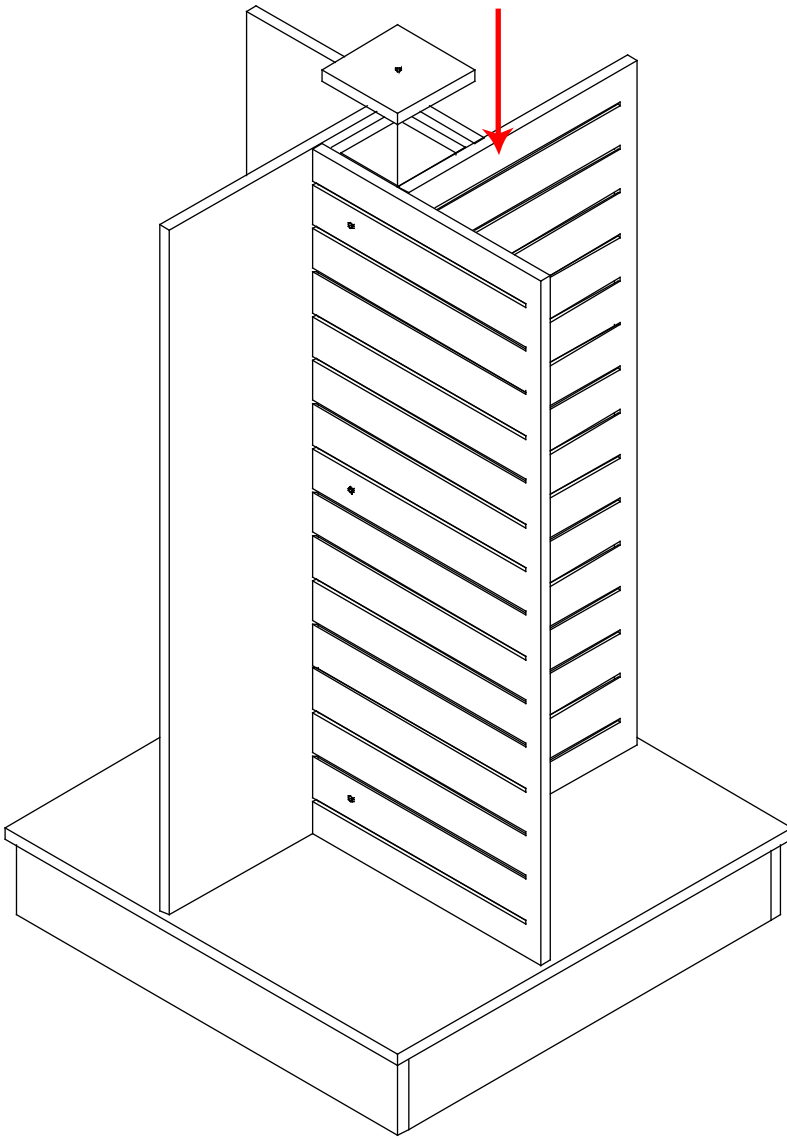

STEP 4: DROP TOP CAP INTO PLACE AS SHOWN.

STEP 5: (IF APPLICABLE) SCREW SWEDGE STEM INTO BOTTOM OF SIGN HOLDER AND DROP INTO RECEPTACLE IN TOP CAP

AM/AS1710

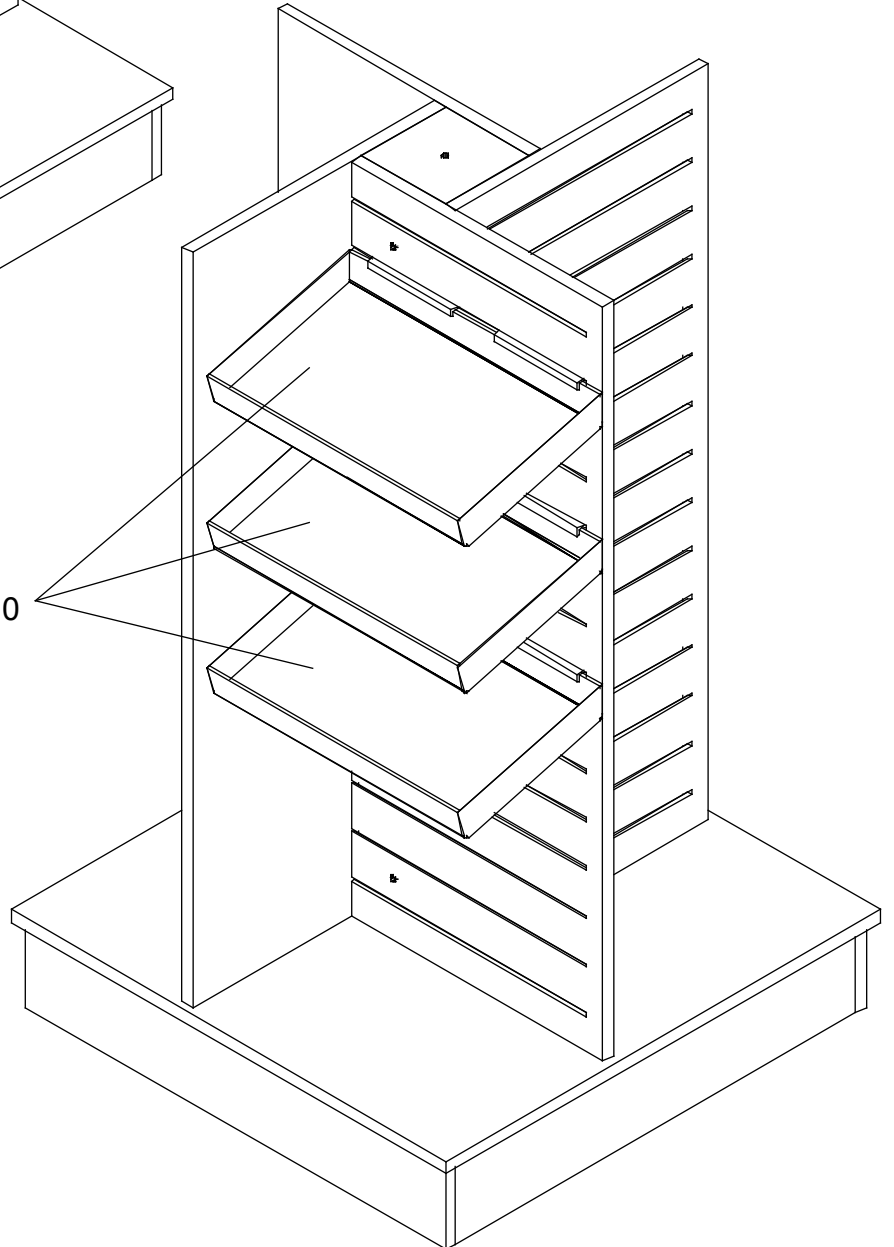

NOTE: ITEM# **AM/AS1710** IS AN ANGLED DESIGNED SPECIFICALLY TO FIT THIS UNIT